

DO NOT SCALE

DIMENSIONS IN mm

METRIC

THIRD ANGLE
PROJECTION



NOTES:

- ⚠ FOR STRIP VERSION SEE DWG. 164155.
- ⚠ UNDERCOATING: 1,3µm Ni.
SELECTIVE : 0,8µm Au.
ZONE I : BRIGHT TIN/LEAD PLATED.
- ⚠ UNDERCOATING: 1,3µm Ni.
SELECTIVE : 0,8µm Au.
REMAINDER : GOLDFLASH.

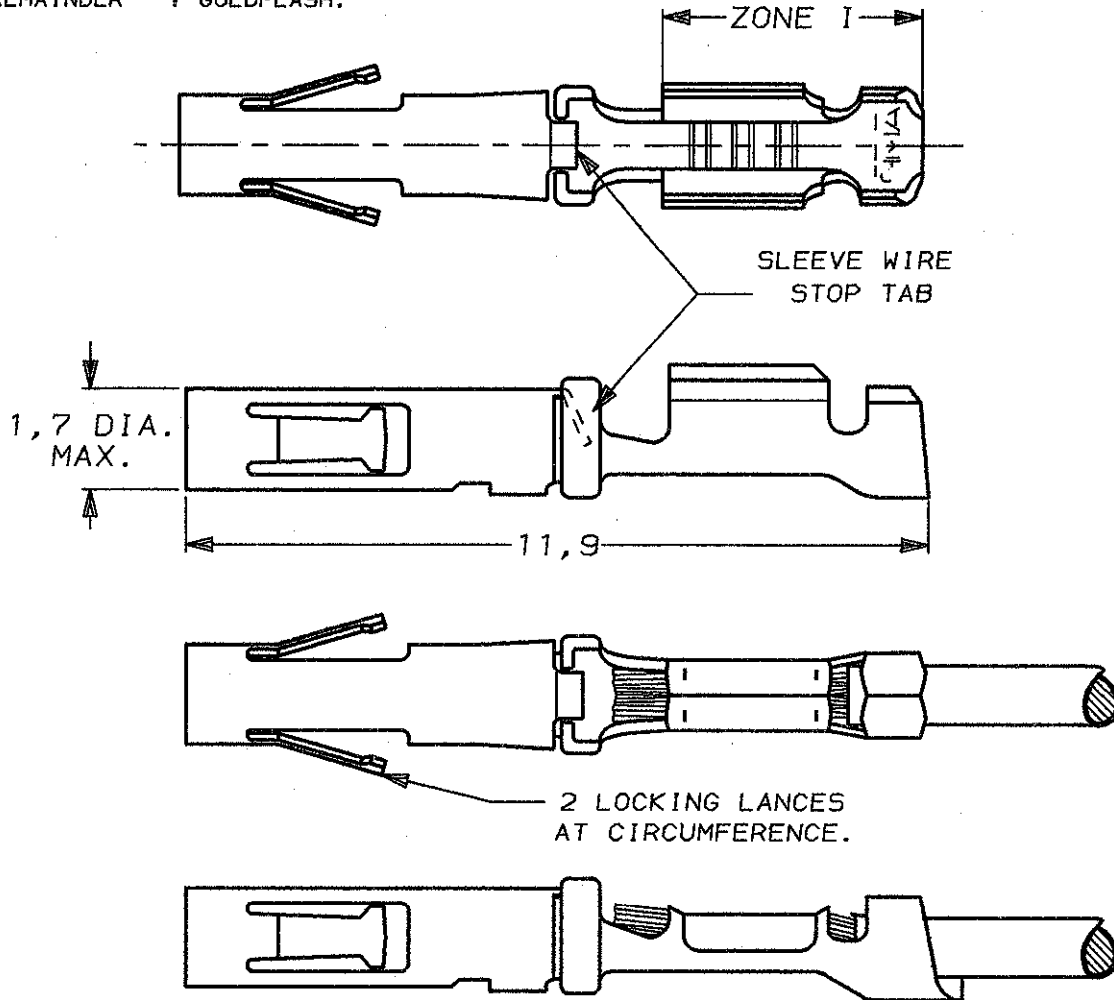

WIRE RANGE :
30-26 AWG 0,05-0,14 mm²
INSULATION RANGE :
1,22 DIA. MAX.

STAINLESS STEEL	SEE NOTE 2	BRASS	164170-4
	PRETINNED		164170-3
	POST TINPLATED		164170-2
	SEE NOTE 3		164170-1
MATERIAL OF SLEEVE	PLATING OF BODY	MATERIAL OF BODY	PARTNUMBER

-	-	-	-	-
-	-	-	-	-
-	-	-	-	-
-	-	-	-	-
-	-	-	-	-
E	EH-0077-92	JvL	CvT	04-03-94
LTR.	REVISION RECORD	DR.	CHK.	DATE

CUSTOMER DRAWING FOR REFERENCE ONLY
WILL NOT BE UPDATED

© COPYRIGHT 19- BY AMP HOLLAND B.V.
ALL INTERNATIONAL RIGHTS RESERVED. AMP PRODUCTS MAY BE
COVERED BY U.S. AND FOREIGN AND/OR PATENTS PENDING.

THIS DRAWING IS UNPUBLISHED
RELEASED FOR PUBLICATION _____, 19____

AMP | AMP HOLLAND B.V.
s-Hertogenbosch,
The Netherlands.

NAME
HDR SOCKET CONTACT
TYPE XI (CRIMP SNAP-IN) L.P.

DR. : J.v.LIEMPT	CHK. : C.v.TILBURG	APP. : L.v.SOEST	DWG.No.	REV.LTR.	SHEET
DATE: 6 JAN 1993	DATE: 08-02-93	DATE: 08-02-93	C-164170	E	1 OF 1